

EDS1000 one -drive-four mode application of constant pressure water

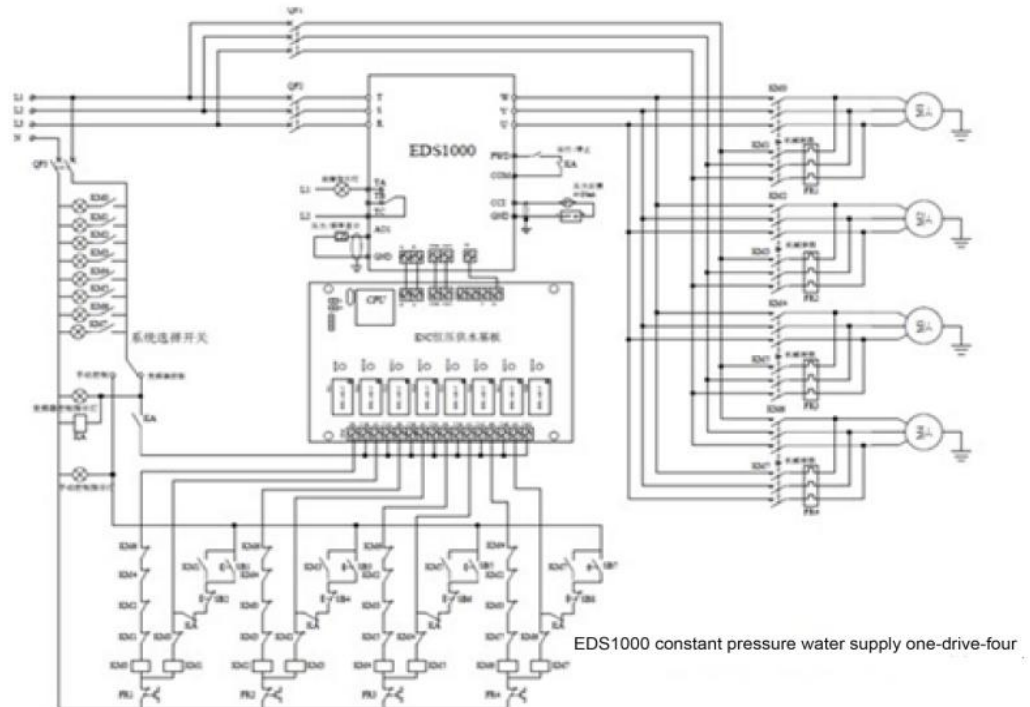

The brief introduction of equipment:

- 1、 One set of EDS1000 series inverter (With free protocol communication, and communicate with water supply board);
- 2、 The constant pressure water supply control board
- 3、 Four pump ;
- 4、 One set of pressure transmitter (current type is the best choice, 4-20mA, is not easy to decay, could be transmission signal for a long distance);
- 5、 Contactor, thermal relay, intermediate relay, button switch, indicator lamp et

Application requirements:

- 1、 The energy-saving principle

For the water pump load, P (power) = Q (flow) * H (head or pressure)

the flow(Q) of pump is in proportion to and speed(N), that is $Q1/Q2=N1/N2=f1/f2$

Pressure or head (H) is proportional to the square of the speed(N), i.e. $H1/H2 = (N1/N2)^2$

Thus power P is proportional to the cube of speed, that is $P1/P2 = (N1/N2)^3$

If the efficiency of the pump fixed, when need adjust the flow down speed N can be reduced in proportion, and the motor output power P is decline in cubic proportion. Therefore, when the inverter to adjust the pump speed, energy saving effect makes the motor speed down is very significant.

- 2、 EDS1000 inverter one-drive-three mode scheme, applied to the scene where in need of large amount of water and need three pumps to work at the same time. there are two modes, manual and automatic switching function model, when the switch to automatic switching mode, it means use the way of closed loop, the inverter running with pump motor and supply water to system, the water supply pipe network transformation on the system translate the actual pressure signal to electric signal and feedback to inverter, inverter automatically adjust pump speed according to the real-time signal transmitter sent, to make the pipe network pressure value at a constant, so as to achieve automatic control and energy saving.
- 3、 When the switch to manual, you can control the pumps operating by-pass or shutdown by manual.
- 4、 The pressure transmitter range recommended choose 1.5-3 times the target pressure value, that means the target pressure values best choose at 1/3-2/3 of pressure transmitter range, it should not set too large to avoid large deviation.

Parameter settings:

- F0.02=1 or F0.02=2: terminal run command control.
- F3.00=2 (Constant pressure water supply is effective)
- F3.01=0 (The pressure given for digital given)
- F3.02=1 (Feedback channel selection CCI)
- F3.03= The target pressure setting (Set according to the requirements, corresponding to the pressure transmitter and pressure gauge range)
- F3.05=20 (When the feedback signal is 4-20mA, need to set this parameter to calibrate the pressure feedback signal)
- F3.16=30Hz(The sleep frequency, can adjust, when the feedback pressure reaches the target pressure, after sleep delay time, frequency enter a state of dormancy to deceleration time decreased to 0.)
- F3.17= Recovery pressure threshold (when the inverter in a dormant state, pressure below this threshold value, after wake up delay time, the inverter frequency recovery, rise, pressure recovery)
- F3.20=3 (Select the constant pressure water supply board do one-drive-four water supply mode)
- F3.21= Pressure gauge or pressure sensor range
- F3.26=1(when this parameter is set to 1, can by monitoring the C-11 (pressure), C-12 (back pressure))
- F3.31=0-2 (Selection of variable frequency circulating mode, effective to the use of constant pressure water supply control board.)
- F5.00=33(The X1 terminal is connected to the water supply board, as external interrupt signal, used for by-pass and frequency switching)

Connection: (there is a wiring diagram explain)