

## EN600 series frequency inverter for rope saw machine application

Rope saw machine is a mountain exploit equipment. The traditional rope saw machine is driven by hydraulic pressure. The hydraulic pump produces hydraulic pressure to drive rotation of motor. The motor drives the driving wheel to rotate. To achieve the purpose of cutting and removing concrete, the driving wheel drives the rope to rotate at high speed in the direction of the control by the driven wheel.

### One. Rope saw machine application

Rope saw machine is a mountain exploit equipment. The traditional rope saw machine is driven by hydraulic pressure. The hydraulic pump produces hydraulic pressure to drive rotation of motor. The motor drives the driving wheel to rotate. To achieve the purpose of cutting and removing concrete, the driving wheel drives the rope to rotate at high speed in the direction of the control by the driven wheel.

Rope saw machine can achieve a variety of thick concrete cutting, to protect the bridge, pier, terminal platform, underwater concrete pile static cutting to ensure that the original structure is not damaged.

[Using EN600 to achieve rope saw machine equipment upgrades, enhance the performance of equipment and automation level.](#)



### Two. Process principle of rope saw machine

The rope saw machine is driven by two motors. The larger one is saw rope motor to drive saw rope, saw rope set in crack of mountain stone and running in high speed. The smaller one is walking motor, driving the saw machine along the direction of the stone was sawing slowly forward. The movement speed of saw machine is adjusted according to the cutting load in real time.

Not only to avoid moving too fast to cause overload or broken rope, but also to avoid moving too slow to cause saw rope twist.

So the rope saw machine not only to ensure that the cutting load uniform and saw rope tension is smooth, but also need to improve the cutting efficiency. The actual shape of the mine irregular, cross-sectional size varies. Moving speed of saw machine need to real-time adjustment, processing technology as shown below.

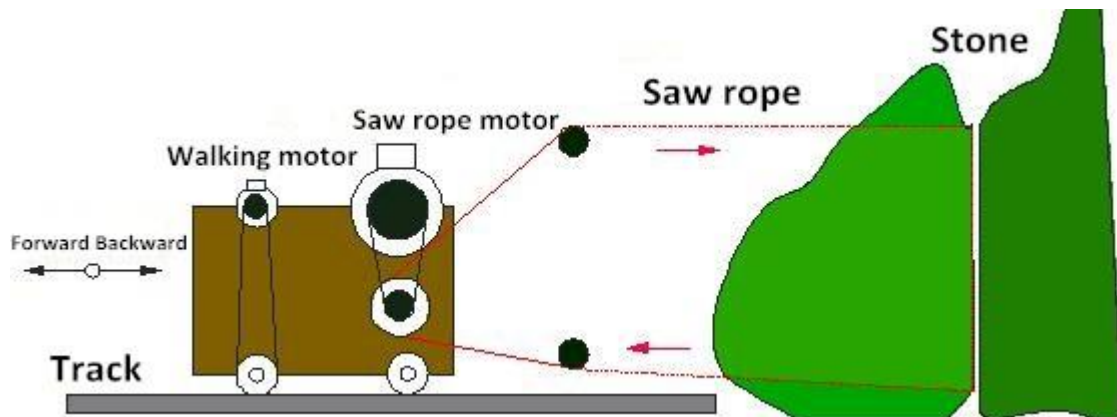

### Three. EN600 frequency inverter rope saw machine control program

#### 1. EN600 program description

The larger power of the saw rope motor and the smaller power of the walking motor are controlled by two frequency inverters respectively. When cutting stones which texture is hard, the current will be large, and the saw machine will slow down until it stops.

The speed of saw rope motor is given by the external potentiometer, and AO1 output is bound to the motor current setting. The frequency inverter of the walking motor carries out the PID operation by collecting the signal given by the saw rope motor frequency inverter AO1, the output frequency controls the speed of walking motor, as shown in the following figure; AI1 of walking motor as a PID given, AI2 signal for the feedback. The output after PID adjustment will control the speed of walking motor, and to ensure that the saw rope motor current stable.

#### 2. Control circuit diagram

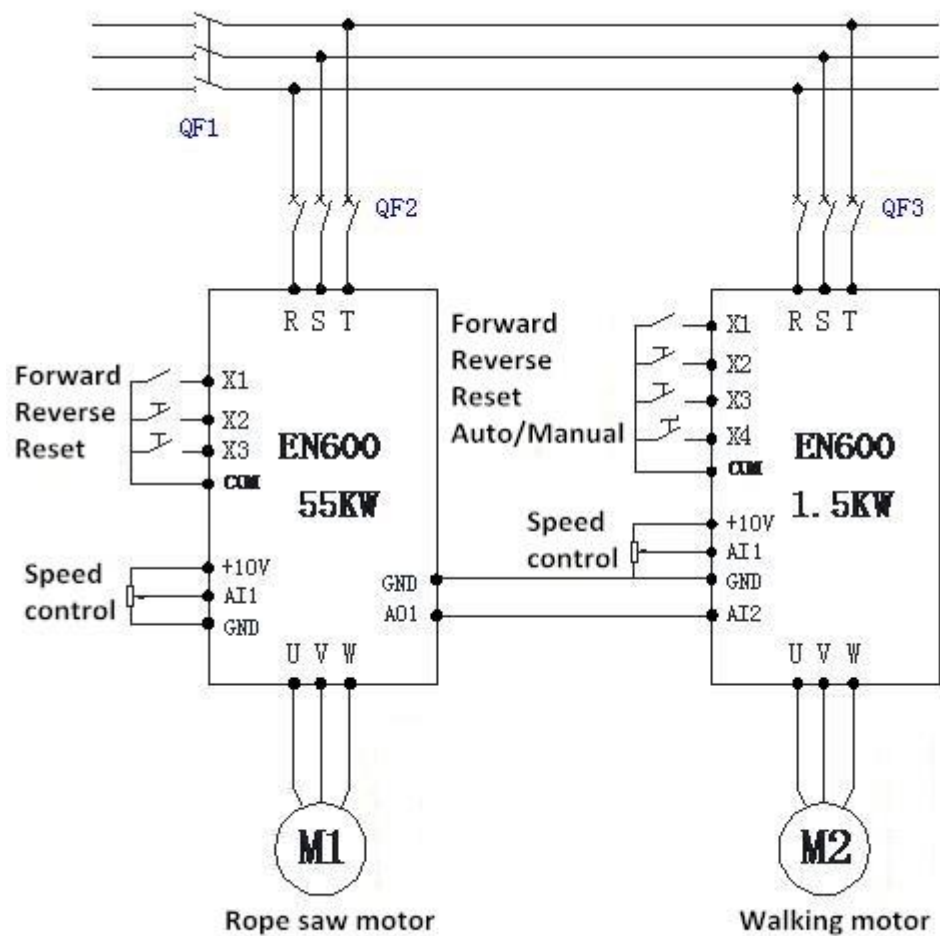

### 3. EN600 frequency inverter unique advantages

- (1) The current of rope saw motor can be accurately expressed by analog value;
- (2) Walking motor PID control is highly automated;
- (3) Excellent low frequency torque characteristics, 150% of the rated torque output at 0.5Hz;
- (4) The output torque can be adjusted;
- (5) Load control is smooth and accurate. It could adjust the speed of movement according to the cutting surface changes. System fluctuation is small;
- (6) Eliminating the need for current transformers and analog input and output modules, reduce the failure rate in mine water, dust and other harsh environments;
- (7) No need for PLC and its programming to reduce debugging trouble.

### 4. EN600 rope saw machine application parameters setting

Table-1 rope saw motor parameters setting:

Function code	Setting value	Explanation
F00.00	2	Senor list mode
F01.00	1	AI1 analog setup
F01.15	1	Terminal running command control
F01.17	15	Acceleration time 15s
F01.18	15	Deceleration time 15s
F08.18	1	X1 forward running
F08.19	2	X2 reverse running
F08.20	24	X3 resetting input
F09.35	5	AO1 output current

Table-2 walking motor parameters setting:

Function code	Setting value	Explanation
F00.00	2	Senor list mode
F01.11	100	Upper limit frequency
F01.15	1	Terminal running command control
F01.17	15	Acceleration time 15s
F01.18	15	Deceleration time 15s
F08.18	1	X1 forward running
F08.19	2	X2 reverse running
F08.20	24	X3 resetting input
F08.21	31	Process PID invalid
F11.00	1	PID close loop run control valid
F11.01	1	AI1 analog provision
F11.02	1	AI2 analog feedback

**Four. EN600 rope saw machine application on site**

